

## Automatic machine for measuring axes

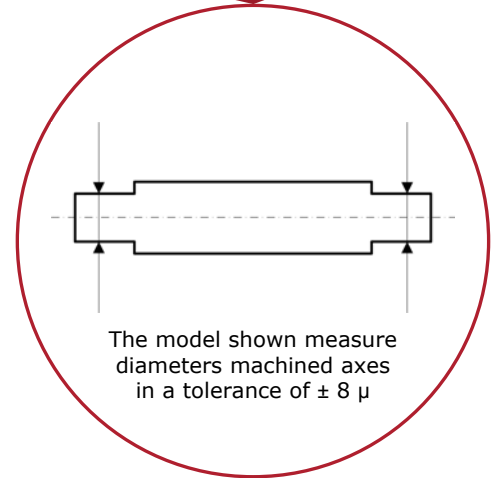
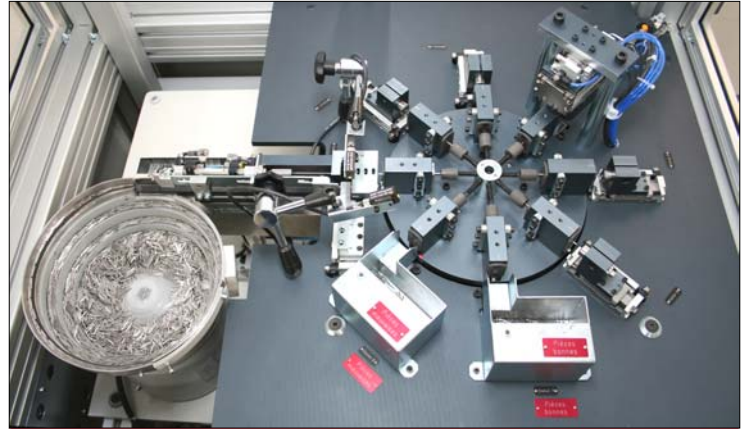

### Characteristics

- H** Continuous operation and productivity gains
- H** Bulk loading in vibrating bowl
- H** Speed of 1'200 workpieces inspected per hour
- H** Type of workpieces: axes from 0,9 - 2 mm
- H** Workpiece turn over station
- H** Separation of workpieces (good and bad)
- H** «LOGIC'HUMARD®» programming with touch screen
- H** Ergonomic design meets EC safety standards

© HUMARD Automation SA / Subject to technical modifications



### HUMARD Automation SA

6, rue St-Randoald  
 CH - 2800 DELEMONT  
 Switzerland  
 Tél. +41 32 421 40 90  
 Fax +41 32 423 29 26  
 www.humard.com  
 info@humard.com

