

Kompakter ROBOTER HUMARD®

angepasst auf CNC Maschine Typ DMG Sauer Ultrasonic 50

Kompakt – Autonom



Masse :

X: 1'270 mm







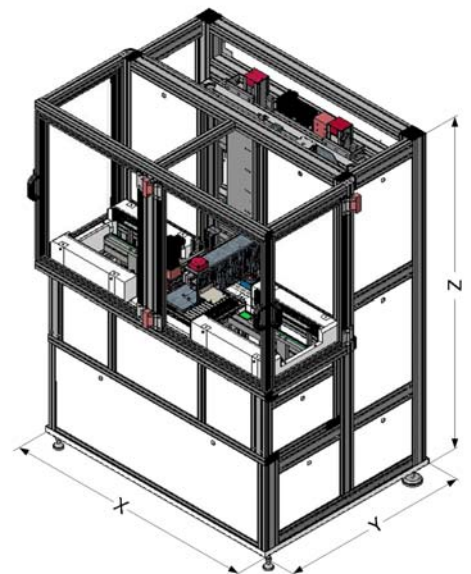

Y: 1'010 mm

Z: 1'900 mm

Platzbedarf : 1.28 m²



Vorteile

-  Wenig Platzbedarf (kompakte Bauart)
-  Anpassbar auf jede CNC Maschine
-  5 Achsen-Steuerung
-  Schneller Wechsel der Werkstücklose
-  Ständiger Lauf für Produktionsgewinn
-  Fernwartung durch Modem
-  Ergonomisches, den CE Sicherheitsnormen entsprechendes Konzept
-  LOGIC'HUMARD® Programmierung mit taktilem Schirm

© HUMARD Automation SA / vorbehaltlich technischer Änderung

CE



HUMARD Automation SA

6, rue St-Randoald
CH - 2800 DELEMONT
Switzerland
Tél. +41 32 421 40 90
Fax +41 32 423 29 26
www.humard.com
info@humard.com